

CLARKE®



BANDSAW

MODEL NO: CBS300/CBS350

PART NO: 6460077 / 6460078

OPERATION & MAINTENANCE INSTRUCTIONS



ORIGINAL INSTRUCTIONS

GC0818-ISSUE 3

INTRODUCTION

Thank you for purchasing this CLARKE Bandsaw.

Before attempting to operate the machine, it is essential that you read this manual thoroughly and carefully follow all instructions given. In doing so you will ensure the safety of yourself and that of others around you, and you can also look forward to the product giving you long and satisfactory service.

GUARANTEE

This CLARKE product is guaranteed against faulty manufacture for a period of 12 months from the date of purchase. Please keep your receipt as proof of purchase.

This guarantee is invalid if the product is found to have been abused or tampered with in any way, or not used for the purpose for which it was intended.

Faulty goods should be returned to their place of purchase, no product can be returned to us without prior permission.

This guarantee does not effect your statutory rights.

ENVIRONMENTAL PROTECTION

Recycle unwanted materials instead of disposing of them as waste. All unwanted accessories and packaging should be sorted and taken to a recycling centre for disposal in a manner which is compatible with the environment.

ENVIRONMENTAL RECYCLING POLICY



Through purchase of this product, the customer is taking on the obligation to deal with the WEEE in accordance with the WEEE regulations in relation to the treatment, recycling & recovery and environmentally sound disposal of the WEEE.

In effect, this means that this product must not be disposed of with general household waste but according to the laws governing Waste Electrical and Electronic Equipment (WEEE) at a recognised disposal facility.

SAFETY WARNINGS



CAUTION: FAILURE TO FOLLOW THESE PRECAUTIONS COULD RESULT IN PERSONAL INJURY, AND/OR DAMAGE TO PROPERTY.

WORK ENVIRONMENT

1. **Keep the work area clean and well lit.** Cluttered and dark areas invite accidents.
2. **Do not operate power tools in explosive atmospheres, such as in the presence of flammable liquids, gases or dust.** Power tools create sparks which may ignite the dust or fumes.
3. **Keep children and bystanders away while operating a power tool. Anyone entering the work area must wear personal protective equipment.**
Distractions can cause you to lose control and fragments of work or a broken disc may fly away and cause injury.
4. **Store power tools properly when not in use.** Abrasive products should be stored in a dry, secure place out of the reach of children.
5. Please read these instructions carefully and retain for future reference.

ELECTRICAL SAFETY

1. **Power tool plugs must match the outlet. Never modify the plug in any way. Do not use adapter plugs with earthed (grounded) power tools.** Unmodified plugs and matching outlets will reduce the risk of electric shock.
2. **Do not expose power tools to rain or wet conditions.** Water entering a power tool will increase the risk of electric shock.
3. **Do not abuse the cord. Never use the cable for carrying, pulling or unplugging the power tool. Keep the cable away from heat, oil, sharp edges or moving parts.** Damaged or entangled cables increase the risk of electric shock.
4. **When operating a power tool outdoors, use an extension cable suitable for outdoor use.** Use of a cable suitable for outdoor use reduces the risk of electric shock.

PERSONAL SAFETY

1. **Stay alert, watch what you are doing and use common sense when operating a power tool.** Do not use a power tool while you are tired or under the influence of drugs, alcohol or medication. A moment of inattention while operating power tools may result in personal injury.

2. **Use personal protective equipment.** Always wear eye protection. Safety equipment such as dust mask, non-skid safety shoes, hearing protection and a workshop apron capable of stopping small abrasive or workpiece fragments.
3. **Avoid accidental starting.** Ensure the switch is in the off position before plugging in. Plugging in power tools that have the switch on invites accidents.
4. **Remove any adjusting key or wrench before turning the power tool on.** A wrench or a key left attached to a rotating part of the power tool may result in personal injury.
5. **Do not overreach.** Keep proper footing and balance at all times. This enables better control of the power tool in unexpected situations. Dress properly. Do not wear loose clothing or jewellery.
6. Keep your hair, clothing and gloves away from moving parts. Loose clothes, jewellery or long hair can be caught in moving parts. Keep the work area clean and tidy.
7. Regularly clean the power tool's air vents. The motor fan will draw dust inside the housing and accumulation of material could cause electrical hazards.
8. **Avoid operator fatigue.** Stop the power tool at regular intervals for a short break to rest hands and arms.
9. **Maintain your tools.** Keep all handles and grips dry and clean.

ELECTRICAL SAFETY

1. Position the power cable so that it cannot be inadvertently pulled or pinched, and where it does not cause a trip hazard.
2. This machine is designed for indoor environments and must not be used for other purposes.
3. If the machine requires repair, always contact your Clarke dealer. Always insist on original spare parts. Repairs carried out by unauthorized persons may be dangerous and invalidate the guarantee.
4. This machine must only be used by adults. Children should not be allowed to play with this appliance.
5. Do not use extension power cables.
6. Before cleaning or maintenance operations, always unplug the machine from the power supply.

POWER TOOL USE AND CARE

1. **Do not force the machine.** Use the correct power tool for your application. It will do a better and safer job at the rate for which it was designed.

2. **Do not use the power tool if the switch does not turn it on and off.** Any power tool that cannot be controlled with the switch is dangerous and must be repaired.
3. **Disconnect the power tool from the power supply before making any adjustments, changing accessories, or storing the tool.** These measures will reduce the risk of the power tool starting accidentally.
4. **Store power tools out of the reach of children and do not allow persons unfamiliar with these instructions to operate the power tool.** Power tools are potentially dangerous in the hands of untrained users.
5. **Maintain power tools in top condition.** Keep tools/ machines clean for the best and safest performance. Check for misalignment or binding of moving parts, broken parts, or any condition that may affect the power tool's operation. If damaged, have the power tool repaired before use. Many accidents are caused by poorly maintained power tools.
6. **Use recommended accessories.** The use of improper accessories could be hazardous.
7. **Machine cleanliness.** Do not allow the ventilation slots in the machine to become blocked with dust.
8. **Check the power tool for damage before using the machine.** Any damaged part should be inspected to ensure that it will operate properly and perform its intended function. Check for alignment of moving parts, breakage of parts, mountings, and any other condition that may affect the machine's operation. Any damage should be properly repaired or the part replaced. If in doubt, DO NOT use the machine. Consult your local dealer.

SERVICING

1. **When necessary, have your power tools serviced or repaired by a qualified person using identical replacement parts.** This will ensure that the safety of the power tool is maintained.

ADDITIONAL PRECAUTIONS FOR BANDSAWS

1. Always check safety guards are in place and functioning correctly before switching the machine on.
2. Always use a push stick, especially on small workpieces.
3. Always use the appropriate saw blade for the material being cut.
4. Never use the machine if the electric cable or plug is in poor condition.
5. Never allow the ventilation slots in the motor to become blocked.
6. Never touch the blade immediately after use, when changing the blade always allow time for it to cool.

7. Never use bent or cracked blades. (Replacement blades are available from your Clarke dealer.
8. Replace table insert if the slot has become enlarged.
9. When cutting wood, ensure all nails or fastenings have been removed beforehand. Nails will damage the saw blade.
10. When cutting boards in an upright position use a suitable push block to prevent kickbacks.
11. When cutting round timber stock, use a suitable jig or fixture to keep the work from turning.
12. Always ensure the blade is fully tightened and correctly adjusted before use.
13. Keep the mains cable well away from the machine and ensure an adequate electrical supply is close at hand so that the operation is not restricted by the length of the cable.
14. Switch the machine off immediately the task is completed.

SAFETY SYMBOLS

The following safety symbols may be found on the machine.



Wear a dust mask



Wear eye protection



Read instruction manual before use

SPECIFICATIONS

	CBS300	CBS350
Weight	50.2 kg	76.8 kg
Dimensions (W x D x H)	770 x 575 x 1586 mm	868 x 670 x 1705 mm
Table Size (W x D)	480 x 390 mm	545 x 515 mm
Throat Width	305 mm	340 mm
Table Height from Floor	990 mm	1005
Table tilt angle	0 - 45°	
Mitre Gauge Range	Left 60° / Right 60°	
Maximum Cutting Depth@90°	165 mm	225 mm
Maximum Cutting Depth@45°	115 mm	160 mm
Blade Length (welded loop)	2240 mm	2560 mm
Blade Width	12.5 mm	
Blade Tooth Pitch	4 tpi	
Blade thickness	0.5 mm	
Supply Cable Length	2100 mm	
Stand Footprint (W x D)	620 x 530 mm	670 x 530 mm
Rated Power @230V	750 W	1100
Blade Speeds	370 or 800 m/min	
Duty Cycle	S1 continuous	
Sound Pressure Level (Lp)	70.7 dB(A)	
Sound Power Level Measured (Lw)	83.7 dB(A)	

ELECTRICAL CONNECTIONS



WARNING! Read these electrical safety instructions thoroughly before connecting the product to the mains supply.

Before switching the product on, make sure that the voltage of your electricity supply is the same as that indicated on the rating plate. This product is designed to operate on 230VAC 50Hz. Connecting it to any other power source may cause damage.

This product may be fitted with a non-rewireable plug. If it is necessary to change the fuse in the plug, the fuse cover must be refitted. If the fuse cover becomes lost or damaged, the plug must not be used until a suitable replacement is obtained.

If the plug has to be changed because it is not suitable for your socket, or due to damage, it should be cut off and a replacement fitted, following the wiring instructions shown below. The old plug must be disposed of safely, as insertion into a mains socket could cause an electrical hazard.



**WARNING! The wires in the power cable of this product are coloured in accordance with the following code:
Blue = Neutral Brown = Live Yellow and Green = Earth**

If the colours of the wires in the power cable of this product do not correspond with the markings on the terminals of your plug, proceed as follows.

- The wire which is coloured **Blue** must be connected to the terminal which is marked **N** or coloured **Black**.
- The wire which is coloured **Brown** must be connected to the terminal which is marked **L** or coloured **Red**.
- The wire which is coloured **Yellow and Green** must be connected to the terminal which is marked **E** or  or coloured **Green**.

Plug must be BS1363/A approved.

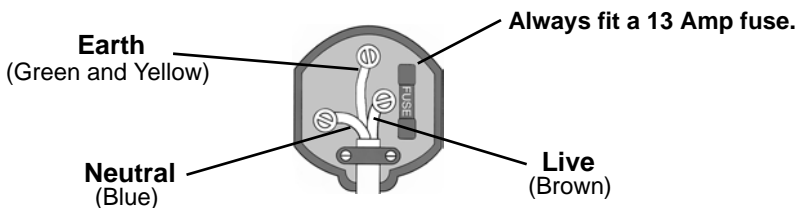

Ensure that the outer sheath of the cable is firmly held by the clamp

We strongly recommend that this machine is connected to the mains supply via a Residual Current Device (RCD)

If in any doubt, consult a qualified electrician. DO NOT attempt any repairs yourself.

OVERVIEW

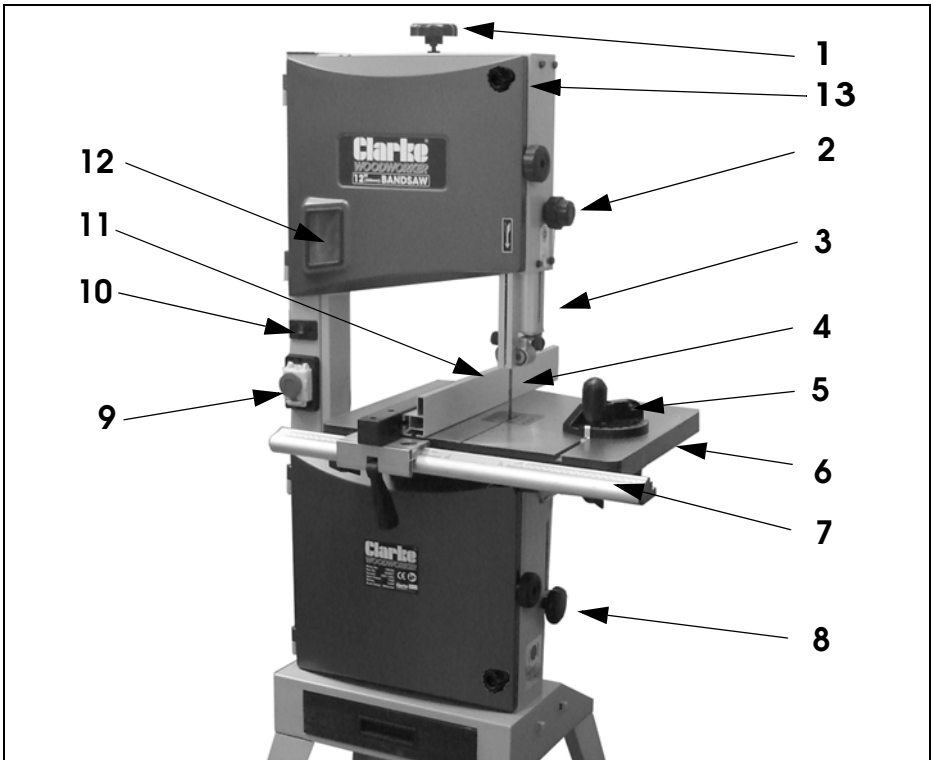

No	DESCRIPTION	No	DESCRIPTION
1	Blade Tension Setting Knob	8	Drive Belt Setting Knob
2	Guide Height Setting Knob	9	Stop button
3	Adjustable Blade Guide	10	LED light switch
4	Bandsaw Blade	11	Rip Fence Assembly
5	Mitre Gauge Assembly	12	Band Tensioner Viewing Window
6	Tilting Work Table	13	Cover Safety Latch
7	Fence Support Guide Rail		

CONTENTS

Ensure the bandsaw and its components suffered no damage during transit and that all components are present. Should any loss or damage be apparent, please contact your CLARKE dealer immediately.

The following components are supplied with the bandsaw assembly.

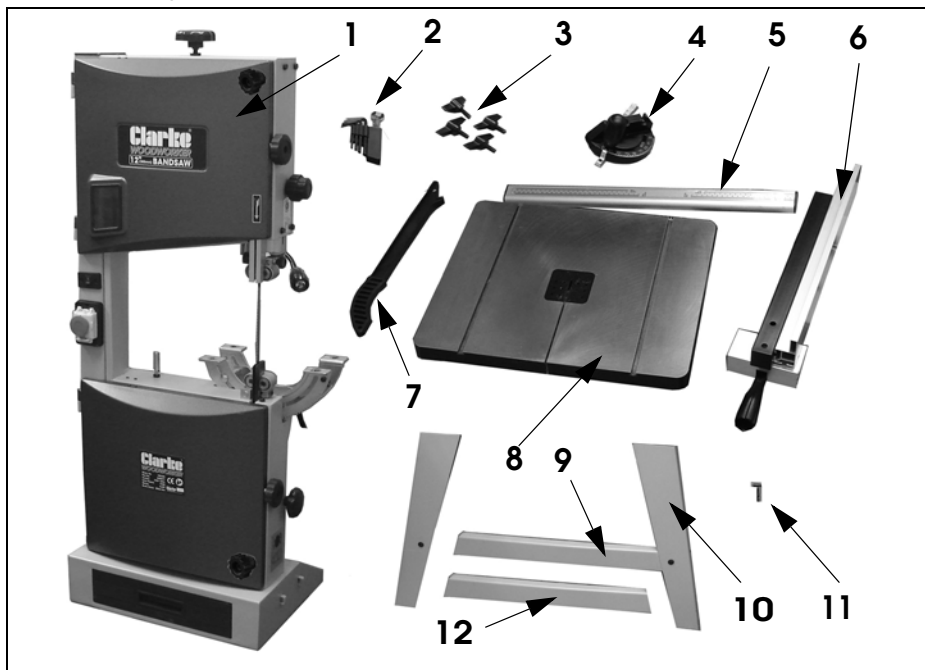

Item	Description	Qty	Item	Description	Qty
1	Bandsaw Assembly	1	7	Push Stick	1
2	Tool (wrench) Set	1	8	Table with Insert	1
3	Guide Rail Fixing Knobs	4	9	Long Braces	2
4	Mitre Gauge Assembly	1	10	Legs	4
5	Guide Rail	1	11	Push Stick Hook	1
6	Rip Fence	1	12	Short Braces	2
Fastenings kit containing:					
	Socket Head Bolts M8 x 12	12		6 mm Flat Washer	8
	8 mm Flat Washers	12		M6 Nut	8
	M6 x 12 Coach Bolts	8		M4 x 10 Screws	2

ASSEMBLY

1. Rest the bandsaw assembly on its side, supported by a block of timber as shown.

- Protect the upper casing from damage with cardboard or rag where it lays on the ground.

2. Attach the legs using the M8 x 12 socket head bolts and 8 mm flat washers.

3. Fit the short and long braces to the legs using M6 x 12 coachbolts, 6 mm flat washers and M6 nuts, inserting the bolts from outside.

- Do not fully tighten the nuts at this stage.

4. Stand the bandsaw upright on level ground and tighten all the bolts and nuts, ensuring the assembly is level.

5. Fit the table to the bandsaw using M8 x 10 bolts and 8 mm flat washers. Ensure the saw blade is central in the table slot.

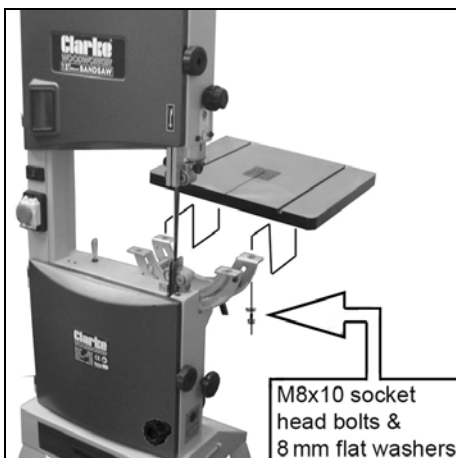
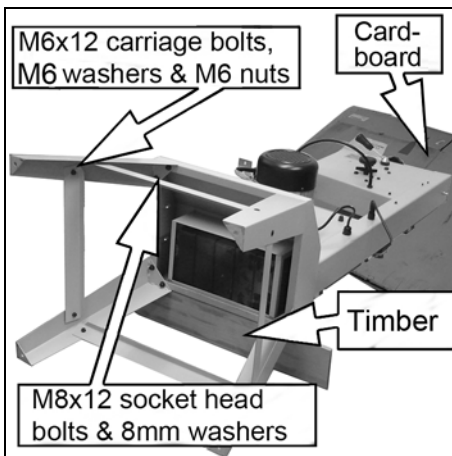

- Secure the guide rail to the table with the four locking knobs.

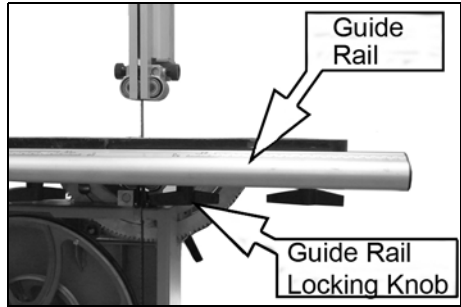

- Fit the tool set holder to the machine frame using the M4x10 screws. Install the loose tools (4 x hex keys and a spanner).
- Fit the push stick hook to the side of the machine and tighten using the unique locking nut.
- Hang the push stick on the hook.
- Fit the rip fence to the table over the guide rail.

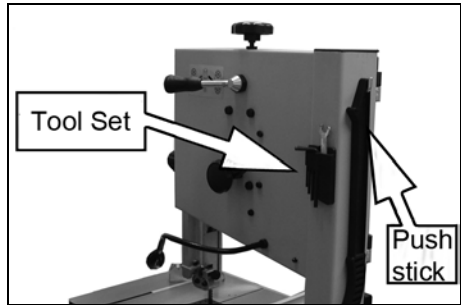

- Store the mitre gauge in the loops provided on the lower frame base.

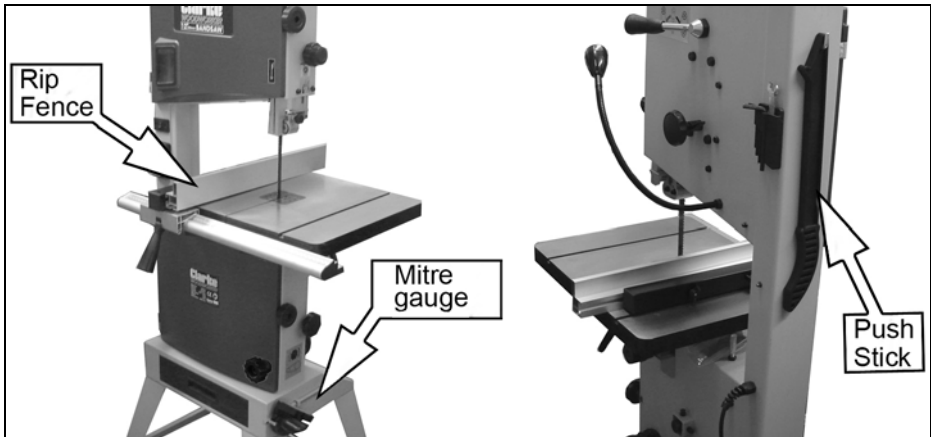

ADJUSTING THE PARTS

TILTING THE TABLE

1. Loosen the locking handle and turn the table tilting knob to adjust the table to the desired angle.
2. Use the angle indicator scale on the table tilting bracket, to find the desired angle.
3. Re-tighten the locking handle to secure the table.
 - For assured accuracy, we recommend checking the tilt angle using a protractor or set square.
4. With the table exactly level, it should rest on the supporting stud shown. Adjust the height of the stud by screwing it in or out of the frame and securing with the locknut. Check with a set square that the table is exactly level when resting on the stud.

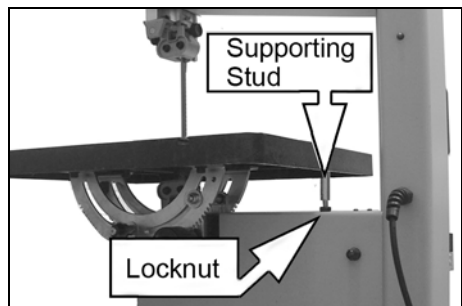
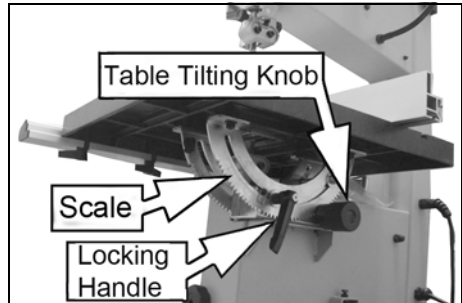

TRACKING THE SAW BLADE

If the saw blade does not run in the centre of the rubber tyre, the tracking needs to be corrected by adjusting the tilt of the upper bandsaw wheel.

1. Open the upper and lower covers by releasing the twist knobs and the safety latches on the front of the machine.
 - Unscrew the safety latches fully to release the cover panels.
 - The panels will not move unless the twist knobs are first released..
2. Loosen the tracking knob and manually rotate the upper wheel, taking care of the sharp blade.

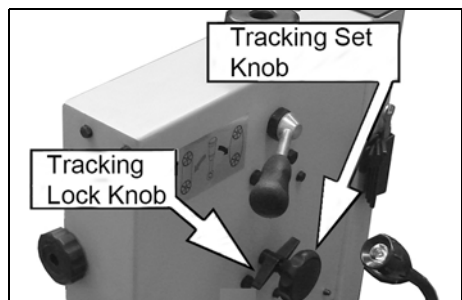

3. Turn the setting knob clockwise or anticlockwise until the saw blade tracks centrally on the rubber tyre.
4. After adjusting, retighten the tracking lock knob and close the covers.

ADJUSTING THE BLADE TENSION



CAUTION: TOO MUCH TENSION CAN CAUSE THE SAW BLADE TO BREAK. TOO LITTLE TENSION CAN CAUSE THE BLADE TO MAKE IRREGULAR CUTS

1. Raise the upper blade guide fully.
2. Check the tension by pressing with a finger against the side of the blade, halfway between the table and upper guide.
 - The blade should not flex more than 2 mm.
3. Turn the blade tension knob to adjust tension.
 - Turning the blade tension knob clockwise will increase the blade tension.

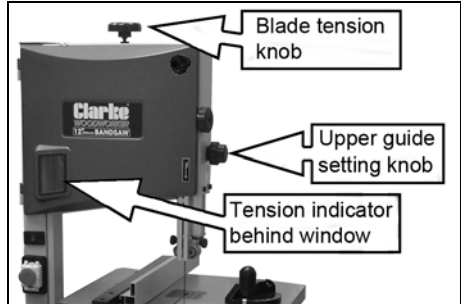

BLADE TENSION INDICATOR

The blade tension indicator set screw shown in the diagram is factory set to the width of the blade supplied (12mm). If a blade of a different width is to be used, you will need to make the following adjustment:

1. With the new blade installed, adjust the blade tension knob until the pointer aligns with the blade width on the scale.
 - The bandsaw can use blades of 6, 10, 12, 16 & 20 mm wide.
 - The scale indicates the correct adjustment, depending on the blade width.

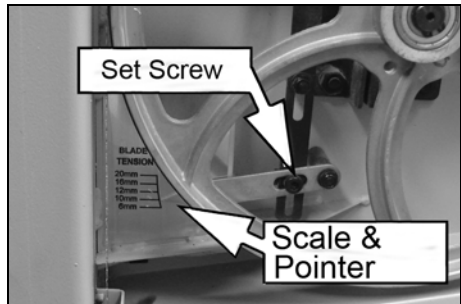

UPPER BLADE GUIDE ADJUSTMENT

GUIDE HEIGHT

The height of the blade guide needs to be adjusted prior to every cutting operation to accommodate the height of the workpiece.

The upper blade guide should be set approx 3 mm above the workpiece.

1. Set the upper blade guide with the adjusting knob to the desired height by loosening the locking knob and re-tightening after adjustment.

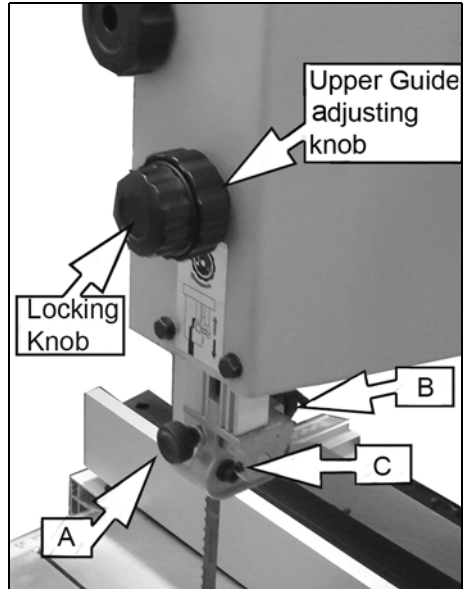

GUIDE BEARING SETTING

2. Loosen the knob, (A) and adjust the blade guide assembly so that the guide bearing is positioned 1 or 2 mm from the back of the blade. Re-tighten the knob (A).
3. Loosen the bolt (C) and adjust the guide bearing to a position 0.5 mm away from the blade. Re-tighten the bolt (C).
4. Loosen the knob, (B) and adjust the thrust bearing to a position, 0.5 mm from the rear of the blade. Re-tighten the knob (B).

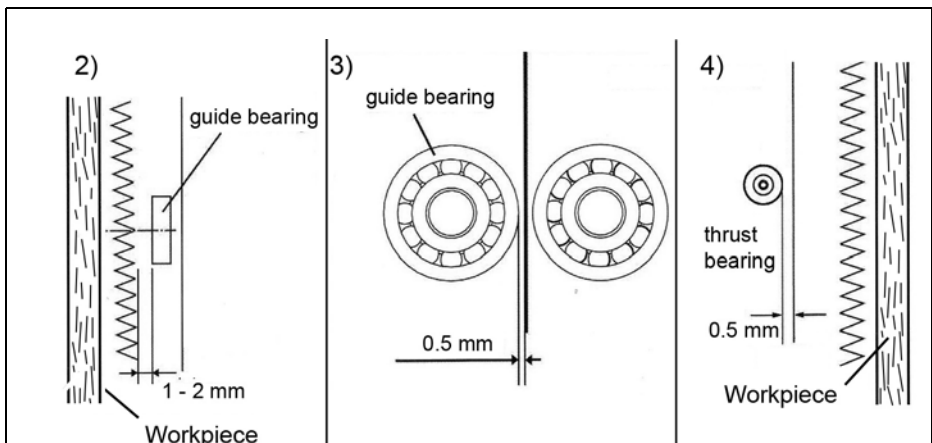

ALIGNING THE LOWER BLADE GUIDE

The lower blade guide needs to be re-adjusted after any blade change or tracking adjustment.

- This task may be easier if the table is tilted for better access.

1. Loosen the screw (D), and move the entire lower blade guide. Adjust the guide bearing to a position of 1 or 2 mm from the back of the blade. Re-tighten the set-screw.
2. Loosen the socket-head bolt (E), and adjust the thrust bearing to a position of 0.5 mm from the rear of the blade. Re-tighten the bolt (E).
3. Loosen the socket head bolts (F), and adjust the guide bearings to a position of 0.5 mm from the sides of the blade. Re-tighten the socket head bolt (F).

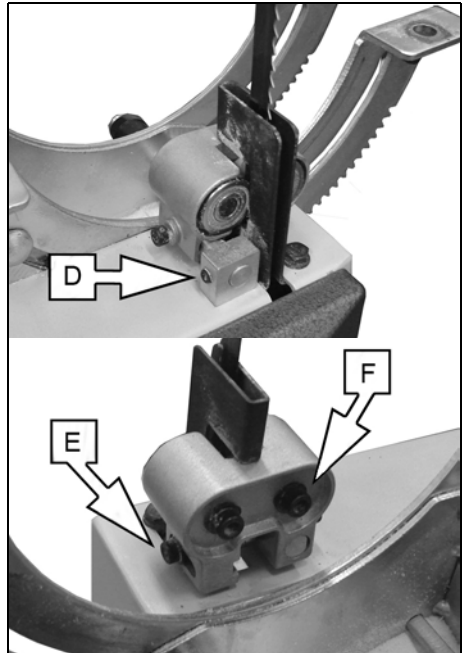

CUTTING SPEED ADJUSTMENT

1. Open the lower cover by twisting the cover release knob.
2. Slacken the driving belt by turning the belt tension knob.

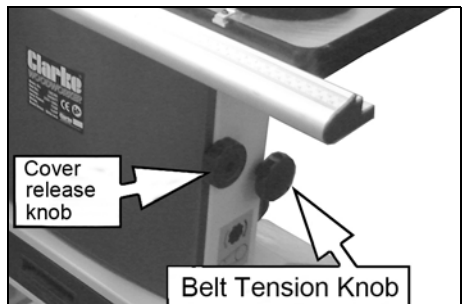

3. Put the driving belt on the required pulley of the driving wheel (lower band-saw wheel) and the corresponding motor pulley.
4. Turn the belt tension knob to adjust the belt tension.

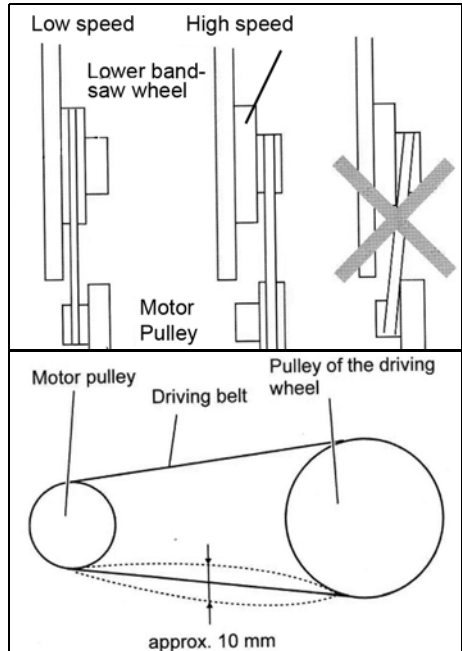

- Turn clockwise to reduce tension/ counter-clockwise to increase tension.
 - Half-way between the pulleys the drive belt should be able to flex approx 10 mm.
5. Close the lower cover.

CHANGING THE SAW BLADE



WARNING: THE TEETH OF THE BLADE ARE SHARP. BE SURE TO WEAR GLOVES WHEN HANDLING THE BLADE IN SITUATIONS SUCH AS UNPACKING, MOUNTING OR REPLACING.

1. Loosen the four lock knobs for the guard rail and remove it.
2. Open the upper and lower covers.
3. Set the upper blade guide to its lowest position.

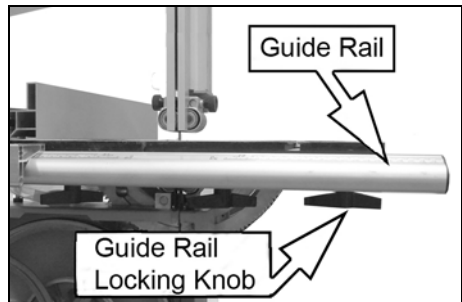

4. Loosen the quick-release lever until the band saw blade has slackened.
5. Remove the saw blade from the machine.
6. Fit a fresh saw blade and centre the blade on the rubber tyres of the wheels.
7. Tighten the quick release lever.
8. Replace the guide rail in its original position.
9. Close the upper & lower covers.
10. Align the blade as described on page 13.
11. Adjust the blade tension as described on page 14.
12. Adjust the upper and lower blade guide as described on pages 14/15.

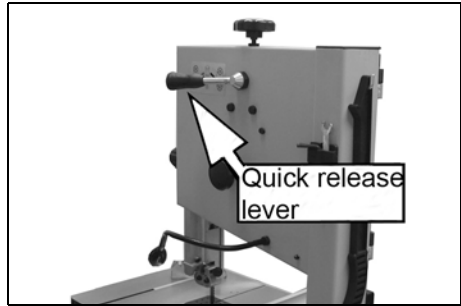

PREPARING FOR WORK

1. Lift the large red stop button, which covers the green 'ON' button and press the green button to start the bandsaw.
2. To stop the machine at any time, press the large red stop button.
3. If required, switch the LED worklight on or off using the rocker switch.
4. Position the flexible LED worklight as required.

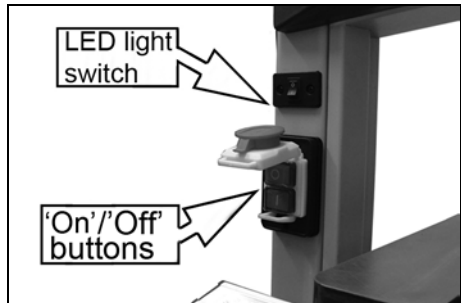

THE RIP FENCE

The rip fence can be used on both sides of the blade. When the fence is re-located from one side to the other, it needs to be reversed as follows.

REVERSING THE FENCE

1. Loosen and remove the two knobs.
2. Take off the fence with bolts and retaining plate from the fence support.
3. Re-fit the fence to the other side and replace the two knobs.

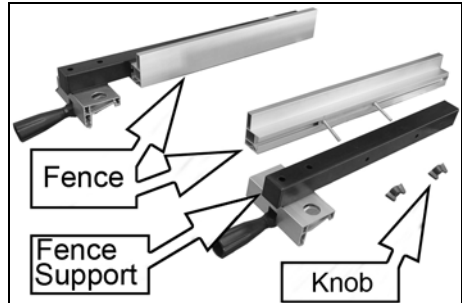

CLAMPING THE RIP FENCE

1. Place the rip fence over the guide rail.
2. Move the fence to the required position. The scale indicates the distance from the saw blade to the fence.
 - Two scales are provided according to whether the fence is set vertically or horizontally as described below.
3. Press down the lock lever to clamp the rip fence in position.

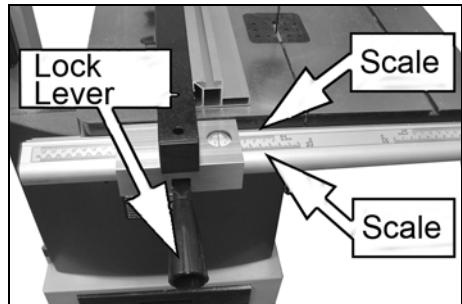

SETTING THE FENCE HEIGHT

The fence can be used in the upright or laying down position. To re-fit the fence to the fence support:

1. Loosen the two knobs (G).
2. Slide the fence out from the fence support.
3. Rotate the fence 90°.
4. Insert the lock screw into the other groove of the fence.
5. Re-tighten the two knobs (G).

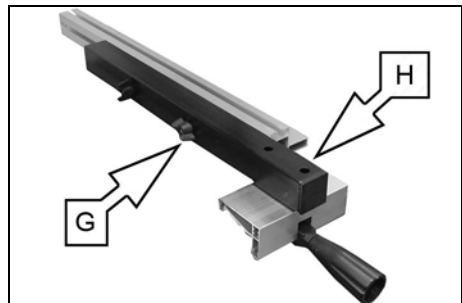

- The fence can be adjusted for accuracy when parallel to the side of the blade by loosening the two socket bolts (H). Check the alignment with a square before tightening the bolts.

ALIGNING THE FENCE WITH THE BLADE

To determine the distance of the fence from the saw blade, the scale on the fence guide rail must be set to line up with the blade.

1. To do this, position the fence so that it just touches the blade while it is free to move along the guide rail.
 2. Loosen the guide rail locking knobs and move the guide rail to the side until the indicator scale is on 'Zero', then re-tighten the knobs
- If the fence is changed to the alternative height, the guide rail will need to be re-set for that configuration.

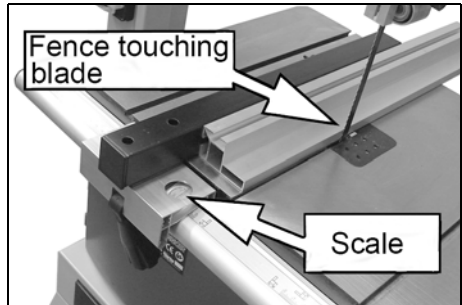

USING THE MITRE GAUGE

The mitre gauge is inserted into the table slot from the front edge.

The mitre gauge can be turned to 60° in both directions.

To set a mitre angle, loosen the lock handle by turning it counter-clockwise. Firmly tighten the handle to secure the mitre gauge in position.

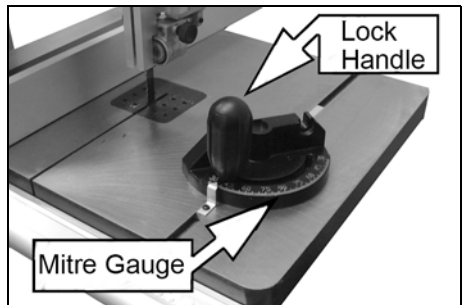

USING THE PUSH STICK

The push-stick serves as an extension of the operators hand as protection against accidentally touching the saw blade.

The push-stick should be used if the distance between the blade and rip fence is less than approx 150 mm.

When not in use, the push-stick can be stored on the hook provided on the bandsaw frame.

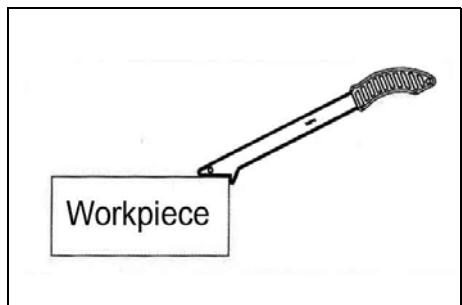

Always replace the push-stick if lost or damaged.

CONNECTING TO A DUST COLLECTOR

This bandsaw is fitted with a dust port for connection to a dust collector if available. Connections are available in the following sizes:

- 50mm o/d
- 75mm o/d
- 100mm o/d

Other sawdust will fall into the dust drawer which can be removed and emptied as required. This is best cleared out regularly.

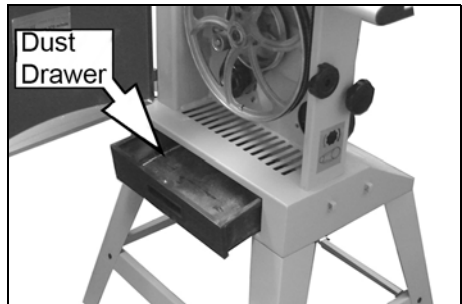
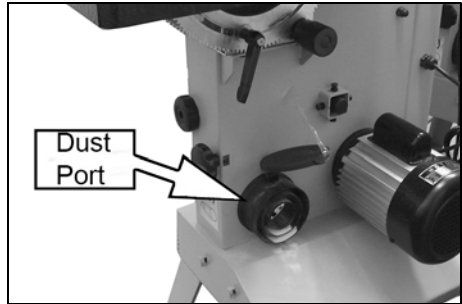

PRACTICAL OPERATION

Before commencing work, ensure the work area is clean and tidy and the machine table is clear of tools etc. Plan your work carefully and set the machine up accordingly before switching on.

- Check the blade is correctly tensioned before use (see page 14).
- Set the upper blade guide as close as practical to the workpiece. This provides the best safety for the operator and giving more accurate results and greater control.
- Adjust the height of the upper blade guide to achieve the best control.
- Switch on and allow the saw blade to reach full speed before proceeding.
- Use both hands to feed the workpiece. The work must be held flat on the table at all times to prevent binding of the blade. Use a steady, even pressure, just sufficient to keep the blade cutting.
- Always use the rip fence or mitre gauge where possible to eliminate any sideways movement of the work. This is most important when the table is tilted at an angle.
- Remember that the blade removes material during the cut creating a gap called the 'kerf', which must be allowed for when cutting to exact sizes.

Plan your cut so that the kerf is the scrap side of the line you wish to cut. Where necessary, allow a little more material for finishing.

- Always use a suitable holding device when cutting round or irregular shaped timber to prevent twisting of the work piece.

TYPES OF CUT

Several types of cut are possible with this saw i.e. rip cutting, cross cutting, bevel or mitre cutting.

RIP CUTTING

This term refers to cutting timber in the same direction as the grain, rather than across it. You can rip wood freehand to a drawn pencil line, but best results are obtained by using the rip fence.

If the table is set level, set the rip-fence to the left hand side of the blade, allowing you to use your right hand to hold the work firmly against the fence.

The scale on the fence guide rail indicates the distance of the fence from the saw blade and can be used as shown on page 20.

When cutting a bevel rip, with the table tilted at any angle up to 45°, set the rip fence to the right hand side of the blade if the width of the workpiece allows it. With the fence on the 'downhill' side of the table, it will help support the workpiece.

The width of cut indicator (scale) on the guide rail may be used to set the rip fence to the required cutting position.

Long workpieces may require additional support in the form of blocks or rollers and may be pulled as well as pushed to pass them through the bandsaw.

CROSS CUTTING

This term refers to cutting timber at right angles to the grain. This type of cut can also be made freehand, but the mitre gauge is used to ensure accurate results. The mitre gauge can be adjusted up to 60° to produce mitre cuts, and with the table tilted, compound mitre cuts.

Make sure the work is held firmly against the table and against the face of the mitre gauge. Be careful to keep your fingers away from the blade, particularly at the end of the cut.

MITRE CUTTING

Most crosscut work, especially with small pieces is more easily controlled with the use of a mitre gauge. The mitre gauge is also essential for accurate compound mitre cuts. The gauge is graduated to 60° for both left and right hand angles.

MAINTENANCE



WARNING: ALWAYS SWITCH OFF THE MACHINE AND DISCONNECT FROM THE POWER SUPPLY BEFORE CARRYING OUT ANY CLEANING OF MAINTENANCE TASKS.

CLEANING

Accumulated dust and chips should be removed from inside the bandsaw frequently as well as emptying the dust drawer. Open the upper and lower covers, use a soft brush and/or vacuum cleaner to remove sawdust. If compressed air is used, ensure it is set to no more than 10 psi.

At the end of every work session, clean sawdust away from the motor vents.

CHANGING THE WHEEL PULLEY TYRES

Eventually the rubber tyres on the bandsaw pulley wheels will wear due to the constant contact with the blade. Remove the saw blade as described on page 17, then lift the edge of the tyre with a small screwdriver and carefully work off the wheel. Ease on the new tyre, ensuring it sits evenly around the wheel.

We recommend that both tyres (item 35, page 27) are changed at the same time.

BLADE GUIDES

Blade guides should be inspected regularly for wear or chipping, and replaced if necessary. See pages 14-16 for blade guide adjustments.

BEARINGS

All bearings used in the construction of your bandsaw and its motor are sealed and lubricated for life.

STORAGE

Switch off the bandsaw and disconnect the power cable.

Cover the machine with a plastic bag and store it in a dry location.

TROUBLESHOOTING

Problem	Check	Solution
The unit fails to operate	<ol style="list-style-type: none"> 1. Check for power failure if the unit is plugged in. 2. Check the switch is on and that the fuse is not blown. 3. Upper or lower door interlock switch not engaged. 	<ol style="list-style-type: none"> 1. Plug the unit into the socket. 2. Replace fuse or switch on. 3. Check that upper/lower doors are fully closed.
Blade breaks	<ol style="list-style-type: none"> 1. Faulty alignment (tracking) 2. Blade guides incorrectly adjusted. 3. Feeding the work too fast. 4. Forcing or twisting the blade around a tight radius. 5. Blade too tight. 6. Blunt teeth. 7. Blade is badly welded or brazed. 8. Wrong blade fitted. 9. Bandsaw left running when not in use. 	<ol style="list-style-type: none"> 1. Carry out tracking adjustments (p13). 2. Readjust blade guides (p14/15) 3. Lower the feed rate 4. For tight curves, make relief cuts fairly close together at 90° to the curve. A narrower blade will make a tighter curve. 5. Relieve blade tension 6. Renew blade 7. Renew blade 8. Fit only quality blades supplied by your Clarke dealer. 9. Always switch machine off when not in use.
Noise or vibration	<ol style="list-style-type: none"> 1. Blade not correctly aligned. 2. Guides not securely set. 	<ol style="list-style-type: none"> 1. Carry out tracking adjustments (p13). 2. Tighten the locking knob. Check guides are correctly set.
Blade runs off the cutting line	<ol style="list-style-type: none"> 1. Blade guides incorrectly adjusted. 2. Blade tracking mal-adjusted 3. Blade tension too slack. 4. Wrong blade fitted (too thin). 	<ol style="list-style-type: none"> 1. Re-adjust blade guides. 2. Carry out tracking adjustment (p13). 3. Re-tension blade. 4. Fit correct blade.

PARTS DIAGRAM

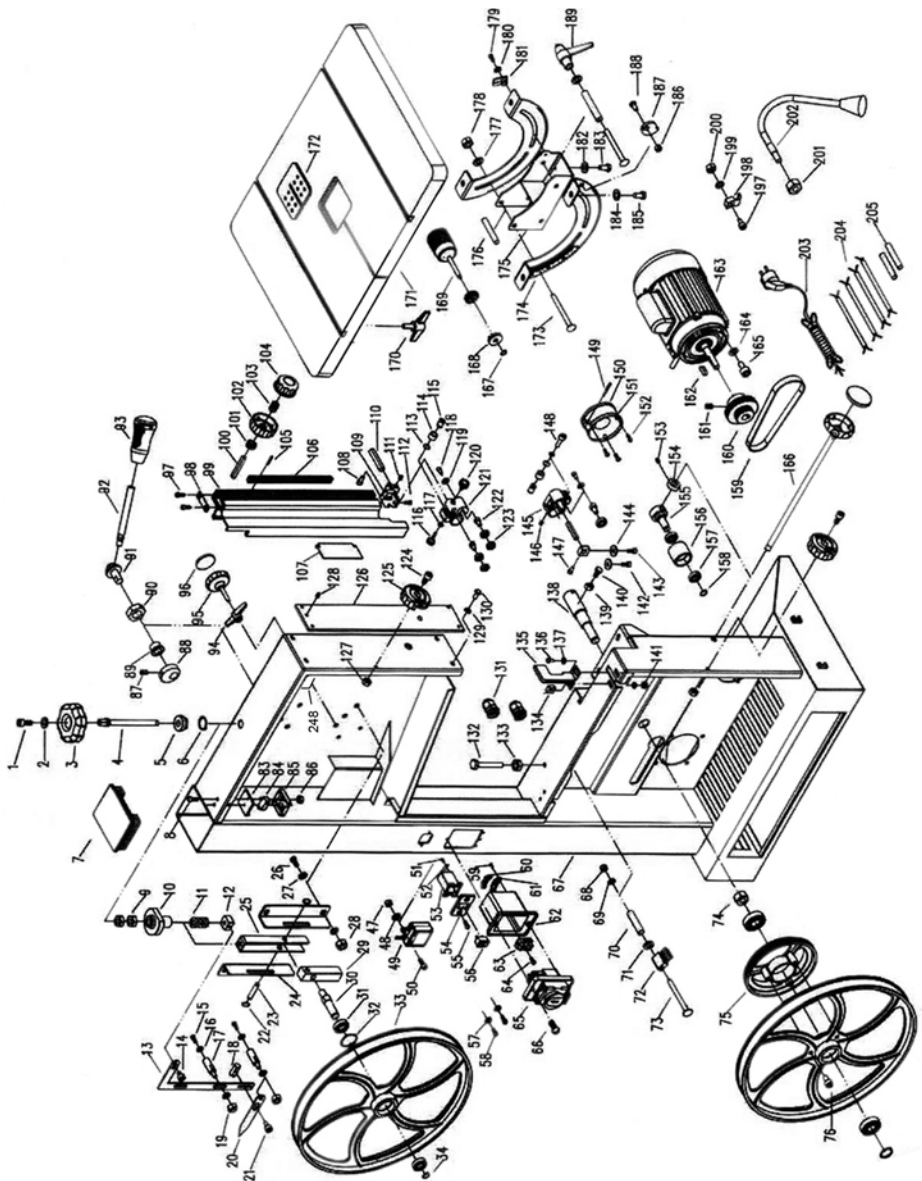

PARTS DIAGRAM

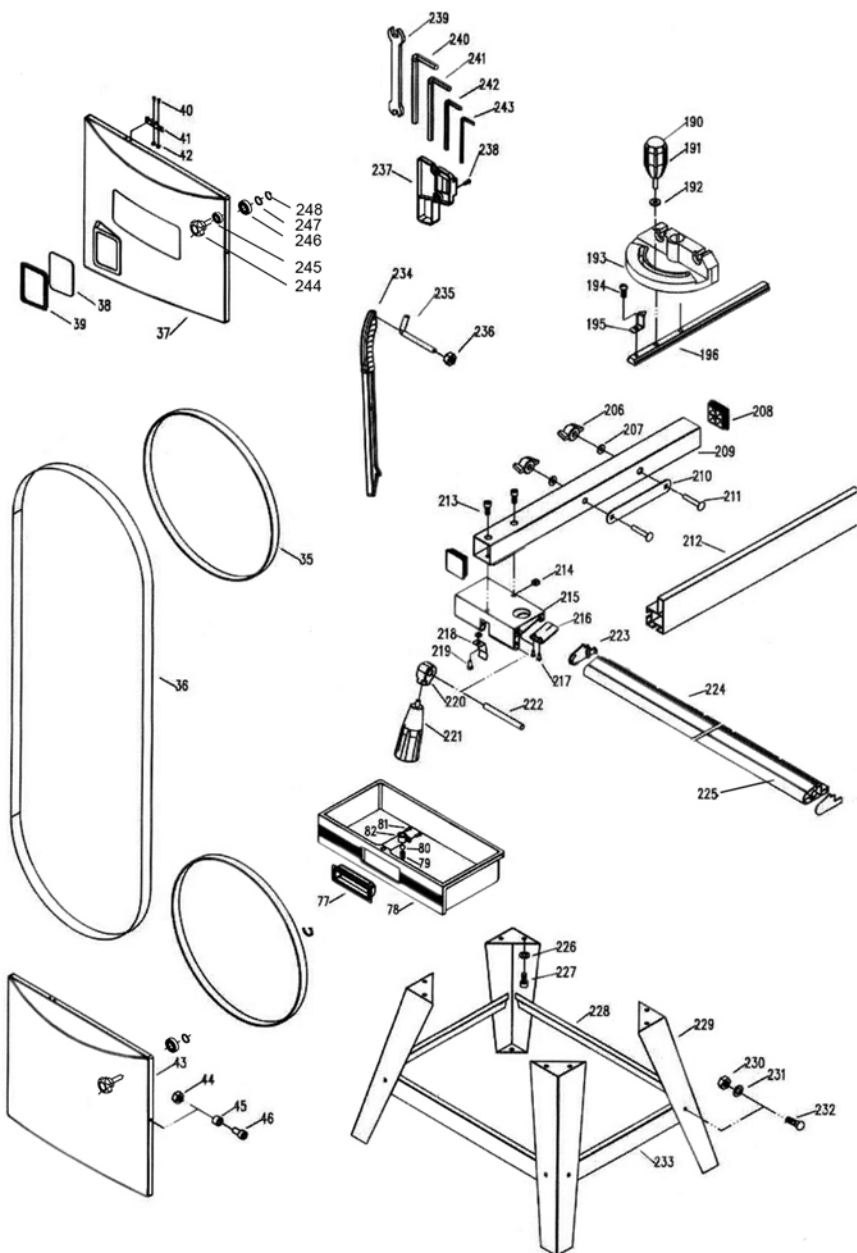

PARTS LIST

PART NO	DESCRIPTION	PART NO	DESCRIPTION
1	5 x 12 socket head screw	35 ##	Wheel Tread
2	5 mm Washer	36 ##	Saw Blade
3	Blade Tension Knob	37 ##	Upper Cover Panel
4 ##	Blade Tensioner Screw	38	Window Glass
5	Spacer	39	Window Seal
6	3AMI-15 Circlip	40	4 x 10 X-head Screw
7 ##	Frame End cap	41	Microswitch Actuating Clip
8	4 x 25 x-head s/t Screw	42	4 mm Nut
9	8 mm Nut	43 ##	Lower Cover Panel
10	Cam	44	6 mm Locknut
11	Tension Coil Spring	45	Closing Spacer
12	Securing Nut	46	6 x 16 mm Socket Head Bolt
13	Pointer Support Plate	47	4 mm Cap Nut
14	Hex head bolt	48	4 mm Flat Washer
15	6 x 12 mm Set Screw	49	LED Worklight Switch
16	6 mm Flat Washer	50	4 x 12 mm Socket Head Screw
17	Stud Bolt	51	4.2 x 9.5 X-head Screw
18	Fixing Block	52	Cable Clamp
19	6 mm Locknut	53	LED Light Switch Box
20 ##	Tension Pointer	54	LED Lamp Switch Face Plate
21	Hinge Bolt	55	4 x 12 mm X-head Screw
22	3AMI-8 Circlip	56	Switch
23	Adjusting Block Arbor	57	4 mm toothed Washer
24	Guide Rail Plate	58	4 x 8 mm X-head Screw
25	Tension Guide Block	59	2.9 x 9.5 x-head Screw
26	8 x 16 mm Set Screw	60	Cable Clamp
27	8 mm Flat Washer	61	Cable Clamp
28	8 mm Nut	62	Switch Box
29	Wheel Adjusting Block	63	Terminal Board
30	Upper Wheel Shaft	64	2.9 x 16 mm X-head Screw
31	Ball Bearing	65	Stop /Start Switch
32	3BMI-35 Circlip	66	4 x 12 mm X-head Screw
33 ##	Bandsaw Pulley	67 ##	Main Frame
34	3AMI-15 Circlip	68	8 mm Domed Nut

PART NO	DESCRIPTION	PART NO	DESCRIPTION
69	8 mm Flat Washer	106	Spring Pin
70	Brush Spacer	107 ##	Guard Plate
71	8 mm Flat Washer	108	6 x 12 mm Socket Head Screw
72	Dust Brush	109	Connecting Block
73	8 x 90 mm Square Head Bolt	110	Connecting Shaft
74	20 x 1.5 mm Nut	111	6 x 8 mm Socket Set Screw
75	Spindle Pulley	112	4.8 x 13 mm X-Head Screw
76	6 x 10 mm Socket Head Bolt	113	10 mm Baffle Ring
77	Draw Handle	114	Needle Bearing
78 ##	Dust Draw	115	Bearing Support
79	Steel Ball Spring	116	Finger Knob
80	8 mm Steel Ball	117	5 mm Flat Washer
81	2.9 x 9.5 mm X-head Screw	118	6 x 16 mm Socket Head Screw
82	Ball Fixing Sleeve	119	6mm Flat Washer
83	Microswitch Box Cover	120	Knob
84	Microswitch	121	Guide Block
85	Microswitch Box	122	Bearing Support
86	4 mm Nut	123	Ball Bearing
87	6 x 8 mm Socket Set Screw	124	6 x 16 mm Socket Head Screw
88	Quick Release Cam	125	Door Closing Handle
89	Cam Axis Guide	126 ##	Guide Plate
90	20 x 1.5 mm Nut	127	6 mm Locknut
91	Cam Shaft	128	6 x 8 mm Socket Head Screw
92	Quick Release Arm	129	6 mm Flat Washer
93	Quick Release Handle	130	6 x 10 mm Socket Head Screw
94	Tracking Lock Knob	131	Cable Gland
95	Tracking Setting Knob	132	Table Stop Rod
96	Handle Cover	133	8 mm Nut
97	4.8 x 13 mm X-head Screw	134	Fixing Block
98	Locating Plate	135	Lower Blade Guide Plate
99 ##	Blade Guard Cover	136	6 x 12 mm Set Screw
100	Spindle	137	6 mm Flat Washer
101	Guide Adjustment Pinion	138	Lower wheel spindle
102	Guide Adjustment Knob	139	6 mm Nut
103	Guide Adjustment Spring	140	6 x 16 mm Set Screw
104	Guide Locking Handle	141	6 mm Nut
105	Rack	142	6 x 8 mm Set Screw

PART NO	DESCRIPTION	PART NO	DESCRIPTION
143	6 x 10 mm Set Screw	180	4 mm Flat Washer
144	6 mm Flat Washer	181	Pointer
145	Lower Guide Block	182	6 mm Flat Washer
146	6 x 8 mm Socket Head Bolt	183	6 x 10 Bolt
147	5 x 10 mm Socket Head Bolt	184	8 mm Flat Washer
148	5 x 25 mm Socket Head Bolt	185	8 x 10 Socket Head Bolt
149	3 x 22 mm Pin	186	6 mm Nut
150	Dust Port Cover	187	Spacing Shim
151	Dust Port	188	6 x 10 Set Bolt
152	4.2 x 13 mm X-Head Screw	189	8mm Locking Handle
153	6 x 8 mm Socket Head Bolt	190	Knob Cap
154	Locating Ring	191	Mitre Lock Handle
155	Tensioner Pulley Spindle	192	Plastic Washer
156	Belt Tension Pulley	193	Mitre Gauge
157	Ball Bearing	194	4 x 8 mm X-Head Screw
158	3AMI-12 Circlip	195	Angle Pointer
159 ##	Drive Belt	196	Mitre Guide Bar
160	Motor Drive Pulley	197	5 x 12 mm Socket Head Screw
161	8 x 8 mm Socket Grub Screw	198	Cable Clamp
162	Key	199	5 mm Flat Washer
163 ##	Drive Motor	200	5 mm Cap Nut
164	6 mm Flat Washer	201	10 mm Retaining Nut
165	6 x 12 mm Socket Head Bolt	202	Flexible LED Lamp
166	Idler Tension Adjusting Rod	203	Power Cable
167	3AMI-18 Circlip	204	Small Cable
168	Table Tilting Pinion Gear	205	Insulator Sleeve
169	Table Tilting Lock Handle	206	Wing-nut
170	Tension Knob	207	6 mm Flat Washer
171 ##	Work Table	208	Plastic End Cap
172	Table Insert	209	Fence Support Bar
173	Square Neck Bolt	210	Fence Securing Plate
174	Table Tilting Bracket	211	6 x 50 mm Coachbolt
175	Rotary Support Bracket	212 ##	Parallel Fence
176	Spacer Sleeve	213	5 x 10 mm Socket Head Bolt
177	8 mm Washer	214	5mm Square Nut
178	8 mm Locknut	215	Fence Mounting Bracket
179	4 x 12 mm X-head screw	216	Plastic Pointer

PART NO	DESCRIPTION	PART NO	DESCRIPTION
217	2.9 x 9.5 mm X-head screw	233	Short Support Beam
218	Fence Locking Leaf Spring	234	Push Stick
219	5 x 8mm X-Head Screw	235	Push Stick Retaining Hook
220	Fence Locking Cam	236	6 mm Nut
221	Fence Locking Lever	237	Tool Holder
222	Fence Locking Spindle	238	4 x 10mm X-Head Screw
223	Guide End Closing Cap	239	8-10 mm Open Wrench
224 ##	Guide Calibrated Scale	240	6 mm Hex (Allen) Key
225	Guide Rail	241	5 mm Hex (Allen) Key
226	8 mm Flat Washer	242	4 mm Hex (Allen) Key
227	8 x 10 Socket Head Bolt	243	3 mm Hex (Allen) Key
228 ##	Long Support Beam	244	Cover Safety Latch Knob
229	Supporting Leg	245	Cover Safety Latch Bush
230	6 mm Nut	246	Cover Safety Latch Spacer
231	6 mm Flat Washer	247	Cover Safety Latch Nut
232	6 x 12 mm Square Head Bolt	248	Cover Safety Latch Circlip

Items marked ## must be specified according to whether CBS300 or 350 model.

DECLARATION OF CONFORMITY



Clarke[®]
INTERNATIONAL

Hemnall Street, Epping, Essex CM16 4LG

DECLARATION OF CONFORMITY

This is an important document and should be retained.

We hereby declare that this product(s) complies with the following directive(s):

2004/108/EC *Electromagnetic Compatibility Directive.*

2006/42/EC *Machinery Directive.*

2011/65/EU *Restriction of Hazardous substances.*

The following standards have been applied to the product(s):

EN 61029-1:2009 +A11:2010, EN 61029-2-5:2011, EN 55014-1:2006 +A2:2011,

EN 55014-2:1997 +A2:2008, EN 61000-3-2:2006 +A2:2009, EN 61000-3-3:2008.

The technical documentation required to demonstrate that the product(s) meet(s) the requirement(s) of the aforementioned directive(s) has been compiled and is available for inspection by the relevant enforcement authorities.

The CE mark was first applied in: 2013

Product Description: Band saw
Model number(s): CBS300, CBS350
Serial / batch Number: N/A
Date of Issue: 05/08/2014

Signed:

J.A. Clarke
Director

A SELECTION FROM THE VAST RANGE OF

Clarke®

QUALITY PRODUCTS

AIR COMPRESSORS

From DIY to industrial, Plus air tools, spray guns and accessories.

GENERATORS

Prime duty or emergency standby for business, home and leisure.

POWER WASHERS

Hot and cold, electric and engine driven - we have what you need

WELDERS

Mig, Arc, Tig and Spot. From DIY to auto/industrial.

METALWORKING

Drills, grinders and saws for DIY and professional use.

WOODWORKING

Saws, sanders, lathes, mortisers and dust extraction.

HYDRAULICS

Cranes, body repair kits, transmission jacks for all types of workshop use.

WATER PUMPS

Submersible, electric and engine driven for DIY, agriculture and industry.

POWERTOOLS

Angle grinders, cordless drill sets, saws and sanders.

STARTERS/CHARGERS

All sizes for car and commercial use.



PARTS & SERVICE: 0208 988 7400

E-mail: Parts@clarkeinternational.com or Service@clarkeinternational.com

SALES: UK 01992 565333 or Export 00 44 (0)1992 565335

Clarke INTERNATIONAL Hemnall Street, Epping, Essex CM16 4LG
www.clarkeinternational.com